

Falns / GATX type 8586B

USAGE

This 4-axle hopper car of the type Falns is used for the transport of non-moisture-sensitive bulk materials such as gravel, crushed gravel, limestone, lignite and hard coal or lignite and hard coal coke.

PAYLOAD TABLE

	A	B1	B2	C	D2	D3	D4
S	38.0t	41.5t	46.0t	56.0t	60.0t	64.0t	
I20				0.0			

PRODUCT DETAILS

Capacity	86.0 m ³
Tare weight	26.0 t
Total weight	90.0 t
Length over buffers	13,500 mm



Scan the QR-code for more details:



#railcarleasingmadeeasier
www.gatx.eu

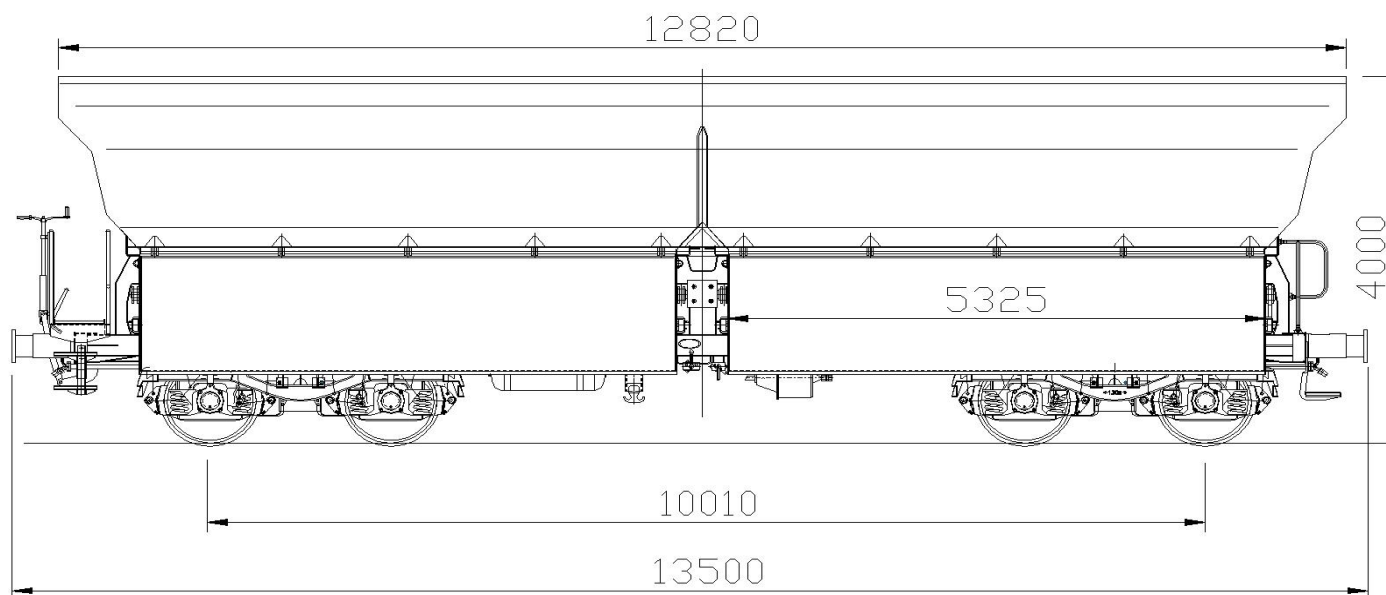

BODY DATA

Body material	normal steel
Saddle material	hardox steel
Maximum width	3,080 mm

LOADING/UNLOADING DEVICES

Loading length	12,820 mm
Loading width	1,954 mm
Length of unloading flaps	5,325 mm
Opening of the side flaps	4,100 mm
Unloading system	pneumatic

