

# Snps / GATX type 9430

## USAGE

The Snps is a bogie flat railcar with a tie-down device. The car is specially designed and suitable for the transport of goods that are not sensitive to moisture, such as logs, sawn timber, long timber, pipes, concrete parts, sectional steel and steel structures.

## PAYLOAD TABLE FOR 10 STANCHIONS

	A	B	C	D
S	41.0 t	49.0 t	59.0 t	67.0 t
I20	0.0			

## PRODUCT DETAILS

Tare weight	23.0 t / 23.5 t
Loading weight	67.0 t / 66.5 t
Total weight	90.0 t
Length over buffers	22,860 mm

## PAYLOAD TABLE FOR 12 STANCHIONS

	A	B	C	D
S	40.5 t	48.5 t	58.5 t	66.5 t
I20	0.0			



Scan the QR-code for more details:



#railcarleasingmadeeasier  
www.gatx.eu

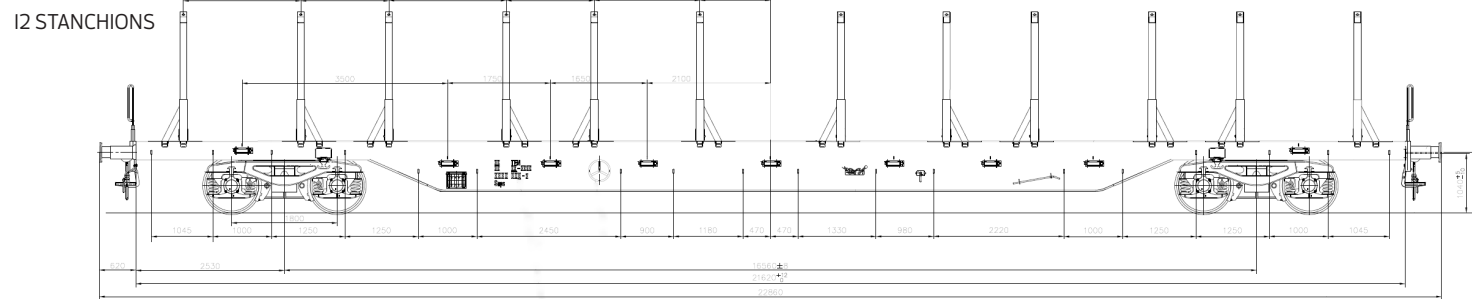
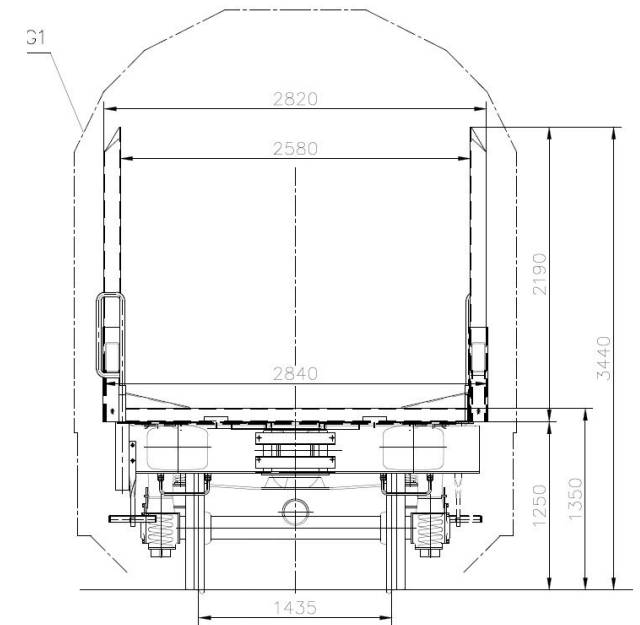
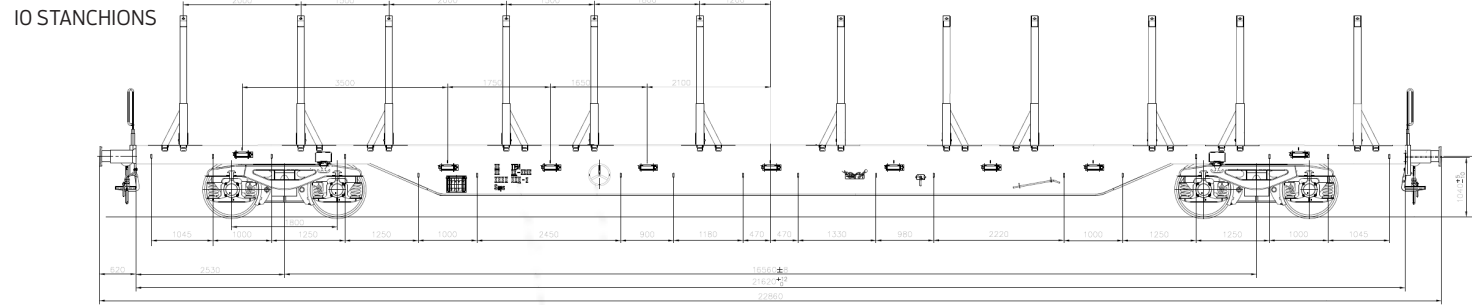

## TECHNICAL DATA

Loading length	21,620 mm
Stakes	10 or 12 pairs
Lashing of the load	9 tie-down devices

## REMARKS

The floor is equipped with a 3 mm thick, walkable tear plate.

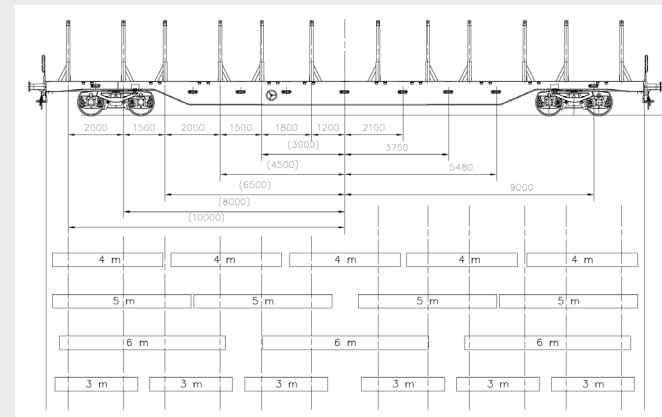

## ALTERNATIVE FITTING WITH STRAIGHT SUPPORT SURFACE FOR SAWN TIMBER

For the transport of sawn timber we straightened the surface between the stanchions. As a result, the contact surface is 120 mm higher. The height to the top of the stanchion is now 1,985 mm. The width of the support surface is 120 mm. The height from TOR to the „new“ support surface increases to 1,470mm. The impact on the tare weight is limited to approx. 300-400 kg.

