

Uacns / GATX type 8073

USAGE

This 4-axle car is designed for the transportation of hazardous products, mainly used for calcium carbide. It can be used for cement and any other non RID product as well.

PAYLOAD TABLE

	A	B	C	D
S	46.7t	54.7t	64.7t	72.7t
I20	0.0			

PRODUCT DETAILS

Capacity	73.0 m ³
Tare weight	17.3 t
Loading weight	72.7 t
Total weight	90.0 t
Length over buffers	14,500 mm
Distance between outer axles	11,260 mm



Scan the
QR-code for
more details:



#railcarleasingmadeeasier
www.gatx.eu

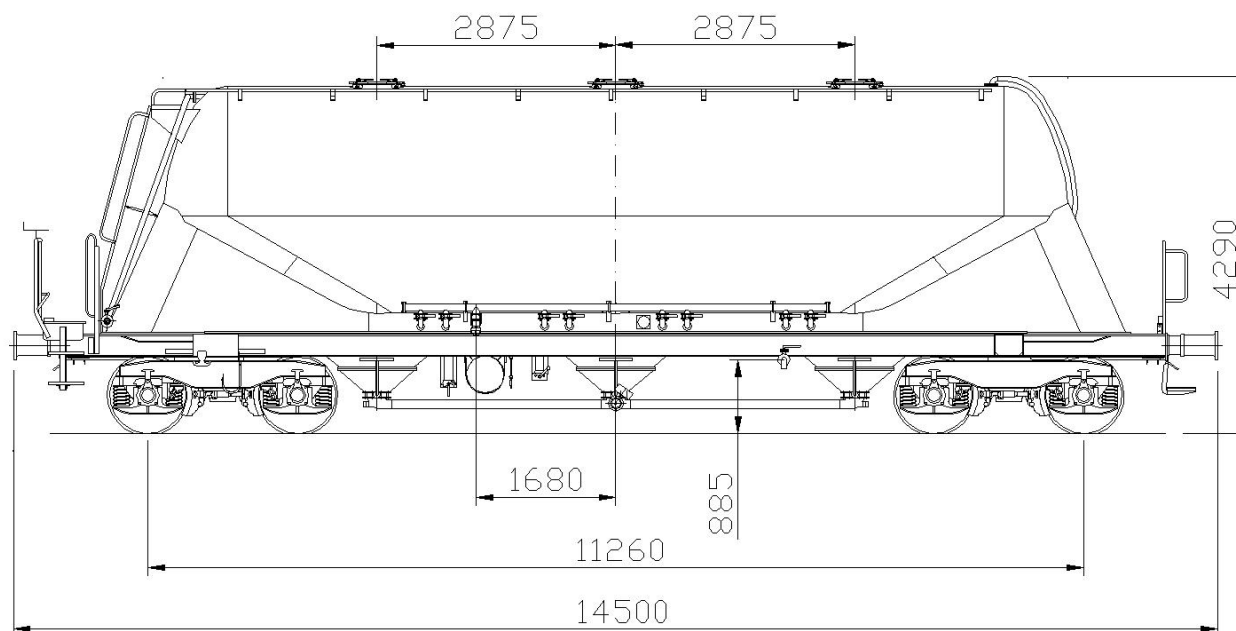

TANK DATA

Tank/Silo material	AW-5186
Working pressure	2.5 bar
Hoppers	3
Tank code	S2,65AN(+)

LOADING/UNLOADING DEVICES

Loading domes	3
Fast sealing cover	DN 500
Filter cloth	yes
Collecting pipe	middle
Product connection	5 ¹ / ₂ " thread
Unloading system	pneumatic
Unloading height	380 mm

