

Uacs / GATX type 8090

USAGE

This 4-axle rail car is used in various sectors for the transportation of pulverized and fine-grain products, such as ash, light soda and pulverized lignite.

PAYLOAD TABLE

	A	B	C
S	37.2t	45.2t	53.2t
I20	0.0		

PRODUCT DETAILS

Capacity	90.0 m ³
Tare weight	26.8 t
Loading weight	53.2 t
Total weight	80.0 t
Length over buffers	19,040 mm
Distance between outer axles	15,800 mm



Scan the
QR-code for
more details:



#railcarleasingmadeeasier
www.gatx.eu

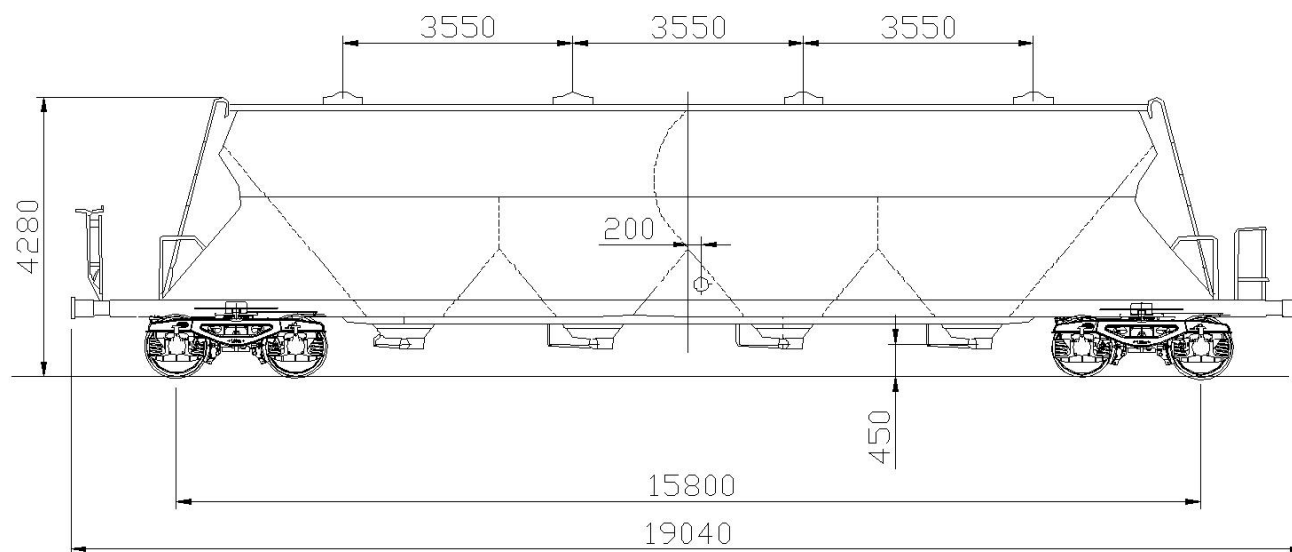

TANK DATA

Tank/Silo material	Steel I.0580
Working pressure	2.5 bar
Hoppers	4

LOADING/UNLOADING DEVICES

Loading domes	4
Fast sealing cover	DN 500
Filter cloth	yes
Collecting pipe	S-shaped
Product connection	5 ¹ / ₂ " thread
Unloading system	pneumatic
Unloading height	450 mm

