

Zacens / GATX type I472

USAGE

This 72m³ car is another grade of evolution in the transport of high viscous materials and oil products. An optimization with respect to length and weight was achieved. This railcar is additionally equipped with heated side valves.

PAYLOAD TABLE

	A	B	C	D
S	41.5 t	49.5 t	59.5 t	67.5 t
I20	0.0			

PRODUCT DETAILS

Capacity	72.0 m ³
Tare weight	22.5 t
Total weight	90.0 t
Length over buffers	14,140 mm



Scan the
QR-code for
more details:



#railcarleasingmadeeasier
www.gatx.eu

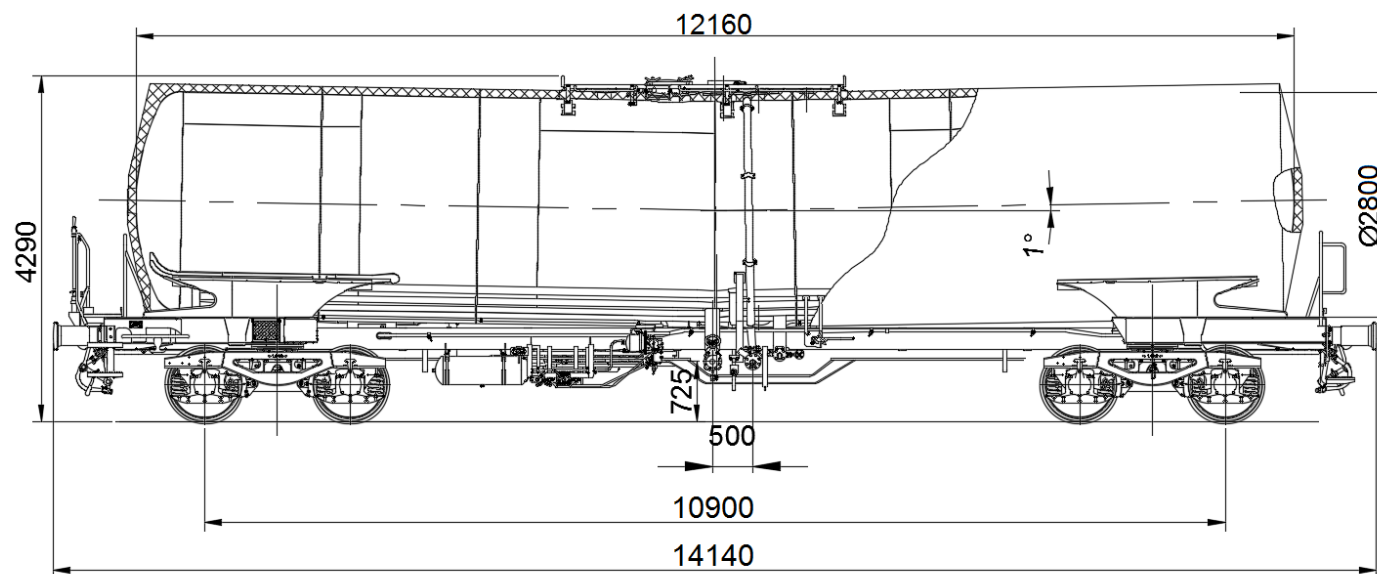

TANK DATA

Tank code	L4BH
Heating/Insulation	Yes

REMARKS

The wagon is equipped with heatable bottom valve, side valves as well as insulated / heatable T-pipe. Special valves may be mounted according to customer requests.

LOADING/UNLOADING DEVICES

Dome	DN 500
Top unloading device	Optional
Floor operated vapour return	Yes
Forced ventilation valve	Yes
Residue discharging	1°
Side valve	DN 100
Bottom valve	DN 125 / 100

