

Zacens / GATX type 5255

USAGE

This 4-axle rail tank car is used for the transportation of various chemical products. The car is optimized for chloroform and sodium hydroxide solution (NaOH).

PAYLOAD TABLE

	A	BI	B2	C	D2	D3	D4
S	43.2t	48.1t	51.2t	61.2t	67.4t	69.2t	
I20	0.0						

PRODUCT DETAILS

Capacity	55.0 m ³
Tare weight	20.8 t
Total weight	90.0 t
Length over buffers	13,790 mm



Scan the
QR-code for
more details:



#railcarleasingmadeeasier
www.gatx.eu

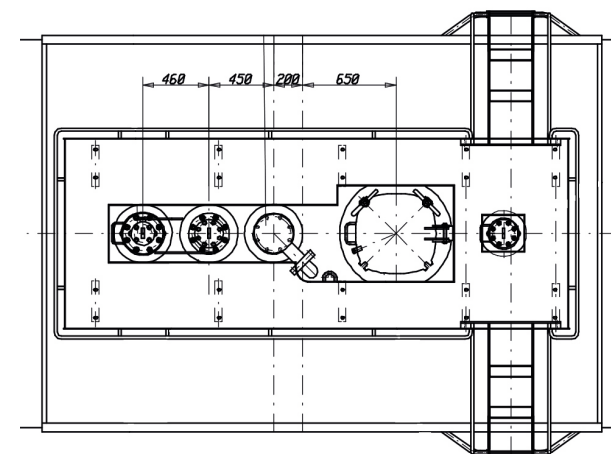
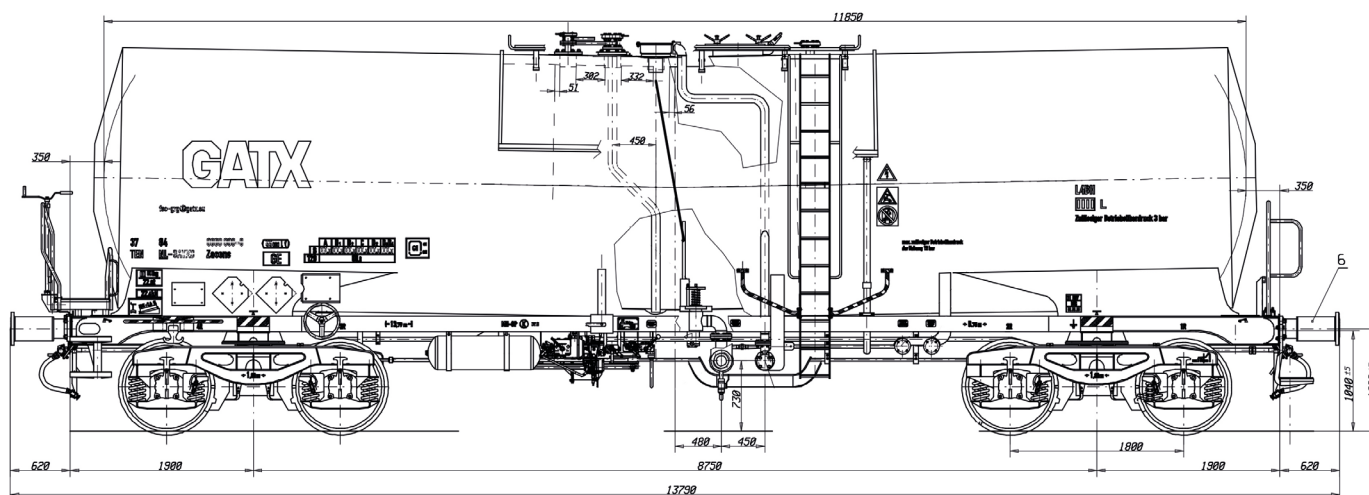

TANK DATA

Tank material	Stainless steel
Tank code	L4BH
Heating/Insulation	Yes
Inner coating	No

REMARKS

The cars can be equipped also with dry couplings on request.

LOADING/UNLOADING DEVICES

Dome	DN 500
Top unloading device	DN 80
Floor operated vapour return	Yes
Forced ventilation valve	Yes
Residue discharging	1°
Side valve	DN 100
Bottom valve	DN 125

