

Zacns / GATX type 5550

USAGE

This 4-axle rail tank car is used for the transportation of highly concentrated nitric acid.

PAYLOAD TABLE

	A	BI	B2	C	D2	D3	D4
S	43.2t	43.5t	51.2t	61.2t	61.5t	69.2t	
I20				0.0			

PRODUCT DETAILS

Capacity	50.0 m ³
Tare weight	20.5 t
Total weight	90.0 t
Length over buffers	12,860 mm



Scan the
QR-code for
more details:



#railcarleasingmadeeasier
www.gatx.eu

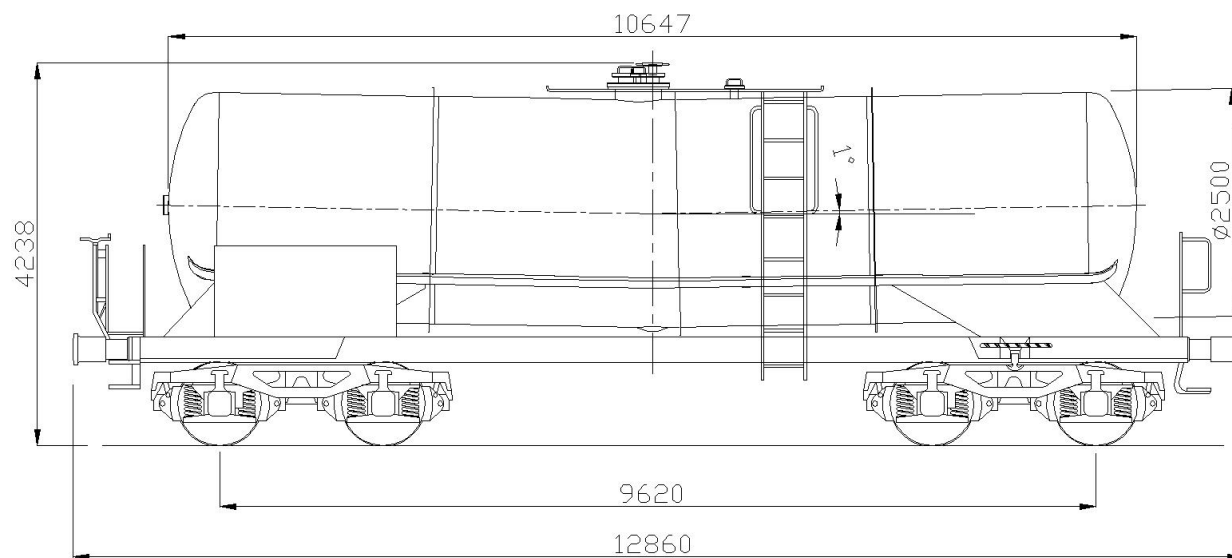

TANK DATA

Tank material	Stainless steel I.436I
Tank code	LIODH
Heating/Insulation	No
Inner coating	No

REMARKS

The tank is made of stainless steel alloy I.436I (URANUS), especially for the transportation of highly concentrated nitric acid.

LOADING/UNLOADING DEVICES

Dome	DN 500
Top unloading device	Yes
Floor operated vapour return	No
Forced ventilation valve	No
Residue discharging	1°
Side valve	No
Bottom valve	No

