

Zagns / GATX type 7182

USAGE

The 4-axled rail tank car is used for the transportation of gases, liquefied under pressure. The construction is optimized for specific gases like Ethylchloride, Methylchloride and Vinylchloride.

PAYLOAD TABLE

	A	B	C	D
S	40.3 t	48.3 t	58.3 t	66.3 t
I20	0.0			

PRODUCT DETAILS

Capacity	82.0 m ³
Tare weight	23.7 t
Total weight	90.0 t
Length over buffers	14,830 mm
Distance between outer axles	11,590 mm



Scan the
QR-code for
more details:



#railcarleasingmadeeasier
www.gatx.eu

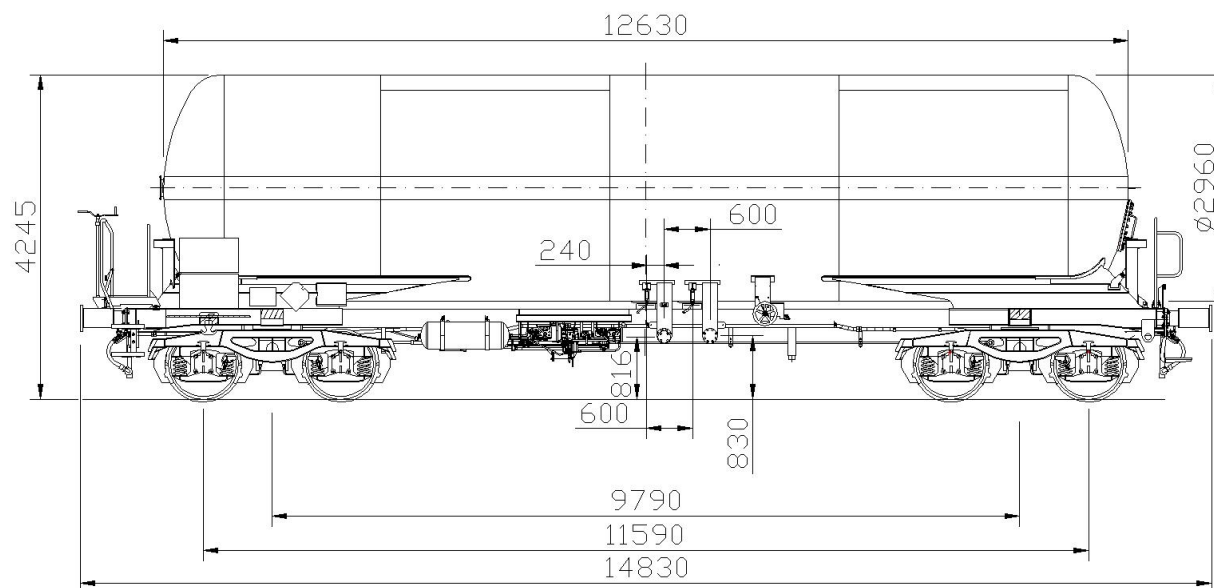

TANK DATA

Tank code	PI5BH
Test pressure	15 bar
Tank material	Fine grained steel
Lowest filling temperature	-40°C
Sun shield	No

LOADING/UNLOADING DEVICES

Side valve liquid phase	DN 80
Side valve gas	DN 50
Bottom valve liquid phase	DN 80
Bottom valve gas phase	DN 80

