

Zags / GATX type 7398

USAGE

The 4-axled rail tank car is used for the transportation of gases, liquefied under pressure.

PAYLOAD TABLE

	A	B	C	D
S	31.0t	39.0t	49.0t	57.0t
I20	0.0			

PRODUCT DETAILS

Capacity	110.0 m ³
Tare weight	33.0 t
Total weight	90.0 t
Length over buffers	18,000 mm
Distance between outer axles	13,900 mm



Scan the
QR-code for
more details:



#railcarleasingmadeeasier
www.gatx.eu

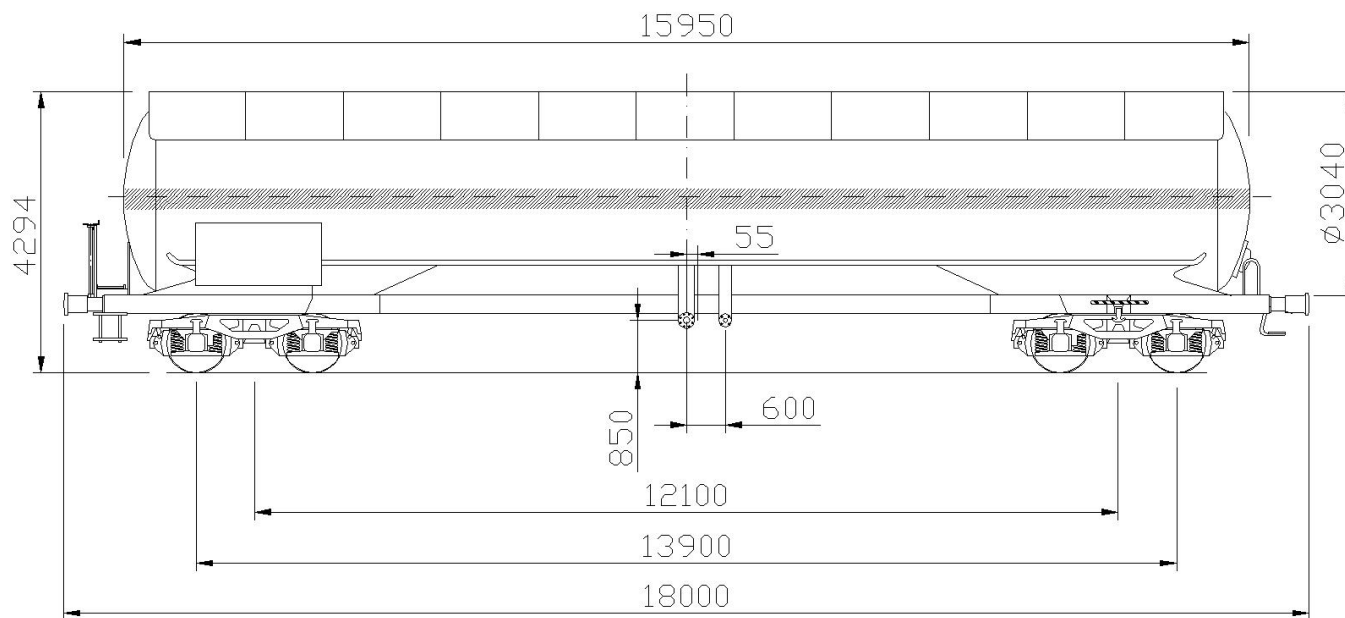

TANK DATA

Tank code	P25BH
Test pressure	25 bar
Tank material	Fine grained steel
Lowest filling temperature	-40 °C
Sun shield	Yes

LOADING/UNLOADING DEVICES

Side valve liquid phase	DN 80
Side valve gas phase	DN 80
reduced to	DN 50
Bottom valve liquid phase	DN 80
Bottom valve gas phase	DN 80

