

# Zags / GATX type 7599

## USAGE

The 4-axled rail tank car is used for the transportation of gases, liquefied under pressure.

## PAYLOAD TABLE

	A	B	C	D
S	28.8 t	36.8 t	46.8 t	54.8 t
I20	0.0			

## PRODUCT DETAILS

Capacity	120.0 m <sup>3</sup>
Tare weight	34.8 t
Total weight	90.0 t
Length over buffers	19,400 mm
Distance between outer axles	15,300 mm



Scan the QR-code for more details:



#railcarleasingmadeeasier  
www.gatx.eu

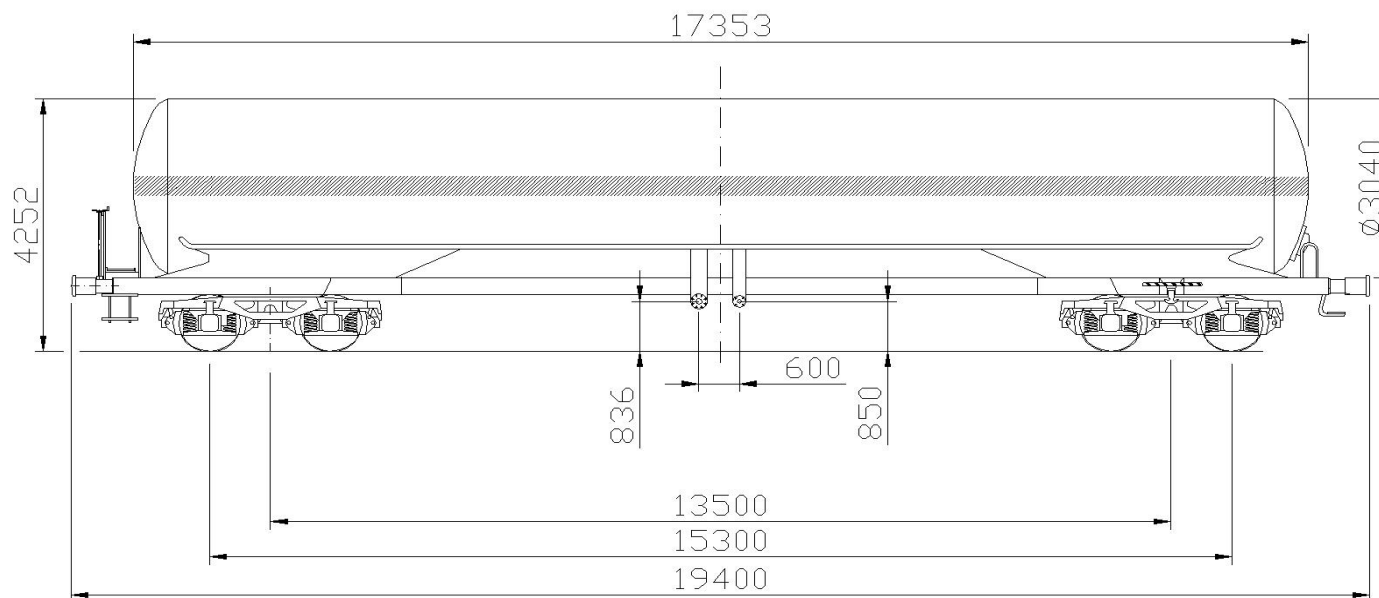

### TANK DATA

Tank code	P27BH
Test pressure	27 bar
Tank material	Fine grained steel
Lowest filling temperature	-40 °C
Sun shield	No

### LOADING/UNLOADING DEVICES

Side valve liquid phase	DN 80
Side valve gas phase	DN 80
reduced to	DN 50
Bottom valve liquid phase	DN 80
Bottom valve gas phase	DN 80

