

# Zans, Zacns / GATX type I688

## USAGE

This car represents a further development stage in the efficient transportation of middle density products (like diesel, light fuel oil and toluene).

## PAYLOAD TABLE

	A	B	C	D
S	43.2t	51.2t	61.2t	69.2t
I20	0.0			

## PRODUCT DETAILS

Capacity	88.0 m <sup>3</sup>
Tare weight	20.8 t
Total weight	90.0 t
Length over buffers	15,240 mm



Scan the QR-code for more details:



#railcarleasingmadeeasier  
www.gatx.eu

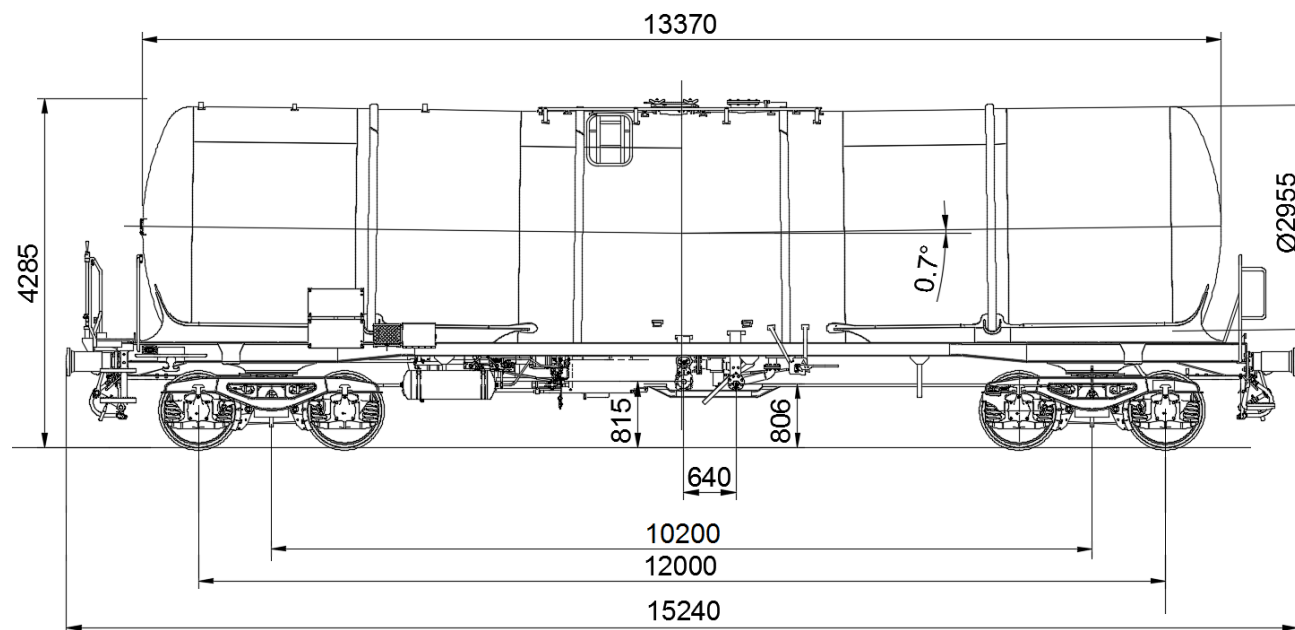

### TANK DATA

Tank code	L4BH
Heating/Insulation	No

### LOADING/UNLOADING DEVICES

Dome	DN 500
Top unloading device	Optional
Floor operated vapour return	Yes
Forced ventilation valve	Yes
Residue discharging	0.7°
Side valve	DN 100
Bottom valve	DN 125 / 100

