

# Zans, Zacns / GATX type I697

## USAGE

The large volume rail tank car known as the second generation "Jumbo" in our industry, impresses with its flexibility and optimization. It is the ideal means of transport for a large variety of liquid goods.

## PAYLOAD TABLE

	A	B	C	D
S	41.4 t	49.4 t	59.4 t	67.4 t
I20	0.0			

## PRODUCT DETAILS

Capacity	97.0 m <sup>3</sup>
Tare weight	22.6 t
Total weight	90.0 t
Length over buffers	16,690 mm



Scan the  
QR-code for  
more details:



#railcarleasingmadeeasier  
[www.gatx.eu](http://www.gatx.eu)

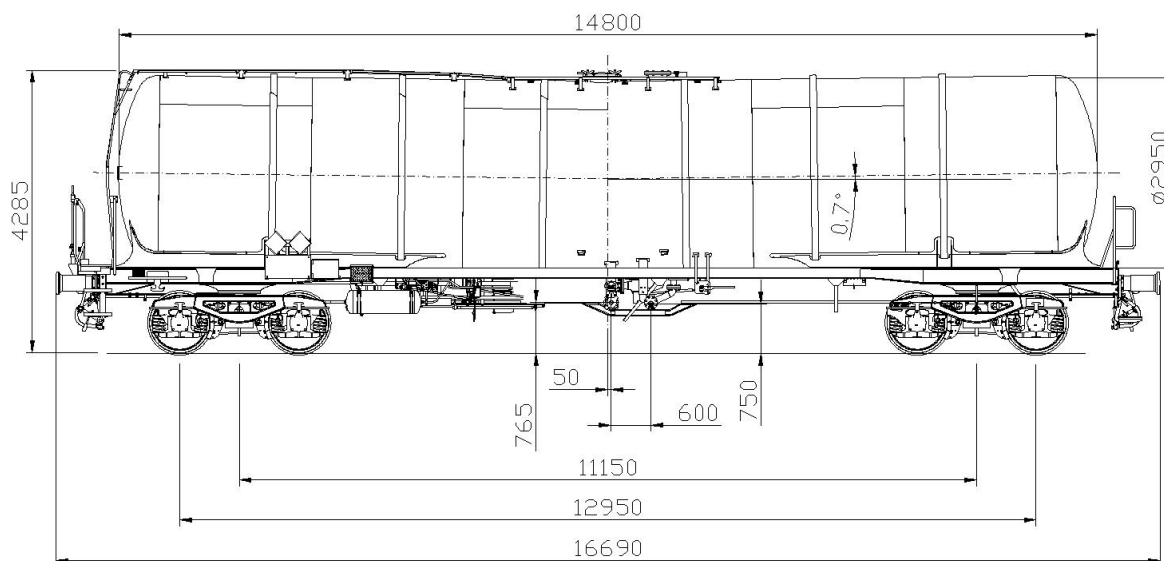

### TANK DATA

Tank code	L4BH
Heating/Insulation	No

### LOADING/UNLOADING DEVICES

Dome	DN 500
Top unloading device	Optional
Floor operated vapour return	Yes
Forced ventilation valve	Yes
Residue discharging	$0.7^\circ$
Side valve	DN 100
Bottom valve	DN 125 / 100

