

Zans / GATX type I698

USAGE

Optimized in further steps we present a highly efficient rail tank car with maximum volume, reduced tare weight and thus an increased total transport capacity. A self-supporting tank is one special feature of this wagon type. Light mineral oil as well as chemical products with low density can be optimally transported.

PAYLOAD TABLE

	A	B	C	D
S	42.2t	50.2t	60.2t	68.2t
I20	0.0			

PRODUCT DETAILS

Capacity	98.0 m ³
Tare weight	21.8 t
Total weight	90.0 t
Length over buffers	16,400 mm



Scan the
QR-code for
more details:



#railcarleasingmadeeasier
www.gatx.eu

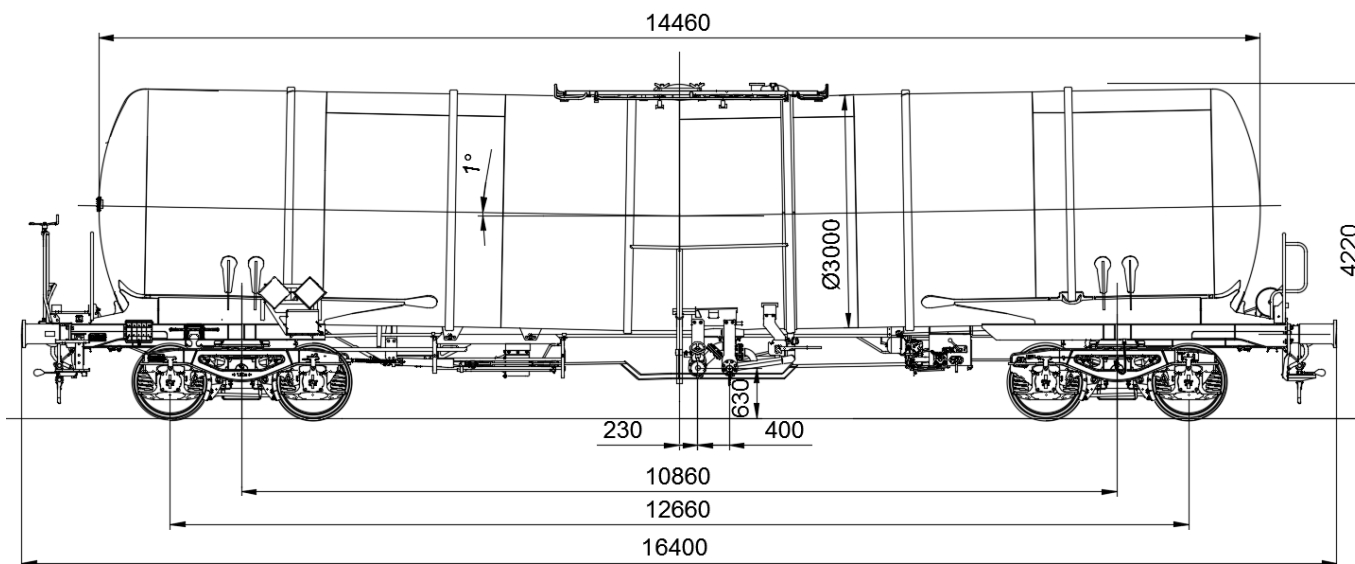

TANK DATA

Tank code	L4BH
Heating/Insulation	No

REMARKS

With the nozzle range on top the car can be optimally adapted to your loading and unloading requirements.

LOADING/UNLOADING DEVICES

Dome	DN 500
Top unloading device	Optional
Floor operated vapour return	Yes
Forced ventilation valve	Yes
Residue discharging	1°
Side valve	DN 100
Bottom valve	DN 125 / 100

