

# Tamns / GATX type 9580

## USAGE

This 4-axle box car, with a modern, two-part swivelling roof, of the type Tamns is used for the transportation of moisture-sensitive bulk materials, such as calcinated coke, FGD gypsum and pet coke. The loading weight of this railcar is 66.0 t.

## PAYLOAD TABLE

	A	B	C	D
S	40.0t	48.0t	58.0t	66.0t
I20	0.0			

## PRODUCT DETAILS

Capacity	80.0 m <sup>3</sup>
Tare weight	24.0 t
Loading area	38.8 m <sup>2</sup>
Total weight	90.0 t
Length over buffers	15,470 mm
Distance between outer axles	10,700 mm



Scan the  
QR-code for  
more details:



#railcarleasingmadeeasier  
[www.gatx.eu](http://www.gatx.eu)

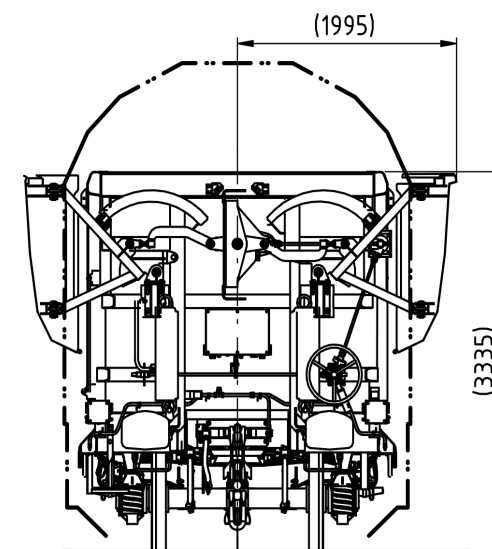
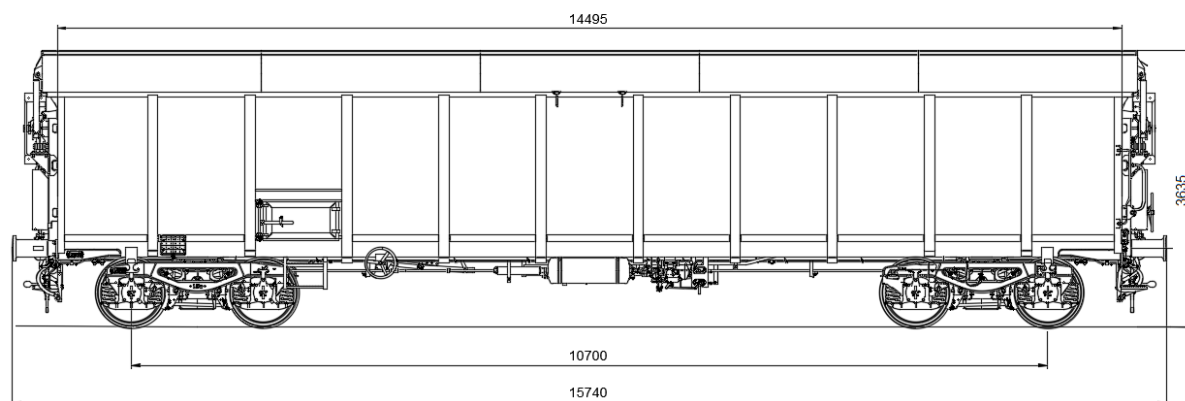

## /// BODY DATA

Body material	steel
Maximum width (closed roof)	2,970 mm
Maximum width (open roof)	3,990 mm

## /// REMARKS

The car is additionally equipped with two inspection and cleaning hatches.

Options for roof operation:

- pneumatic (air supply of locomotive, compressor)
- by handwheel
- by impact wrench (square shaft)

## /// LOADING/UNLOADING DEVICES

Loading length	14,495 mm
Loading width	2,580 mm

Scan the  
QR-code for  
more details:

