

Tagnpps / GATX type 8595

USAGE

This 4-axled hopper car of the type Tagnpps is used for the transportation of grain like corn, wheat, barley, rice corn, rape, sunflower, rye, oat or soy.

PAYLOAD TABLE

	A	B	C	D
S	43.9 t	51.9 t	61.9 t	69.9 t
I20	0.0			

PRODUCT DETAILS

Capacity	95.0 m ³
Tare weight	20.1 t
Total weight	90.0 t
Length over buffers	14,800 mm
Length unloading hatches (per flap)	1,350 mm



Scan the
QR-code for
more details:



#railcarleasingmadeeasier
www.gatx.eu

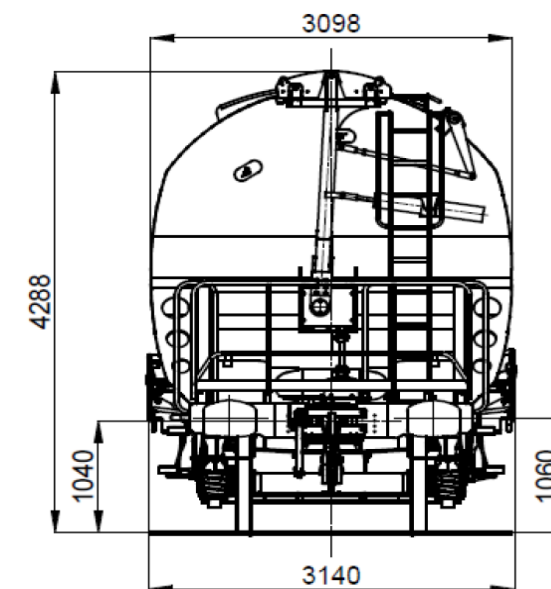
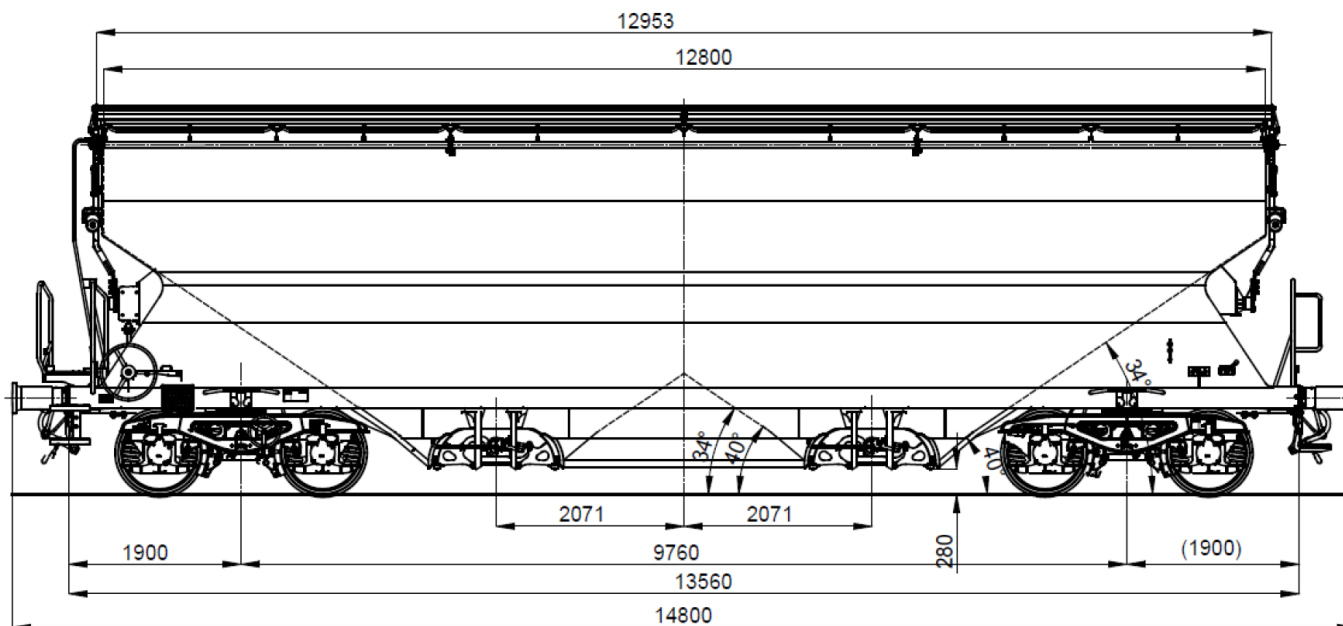

BODY DATA

Body material	normal steel
Maximum width	3,140 mm

REMARKS

The car has been weight optimized for maximum payload.
The roof is operated from the ground level, on one wagon end, on both wagon sides, by operating a hand wheel.

LOADING/UNLOADING DEVICES

Loading length	12,800 mm
Loading width	800 mm
Height of the chute above T. R.	280 mm
Unloading chutes	4
Unloading system	manually
Dimension of discharge openings	320 x 1,350 mm
Clearance gauge	G1

